

GEIPEL-Spiegelrastereinbauleuchte Typ EK24

GEIPEL-Recessed luminaire with parabolic reflector grid type EK24



**Einlegeleuchte Typ EK24 Modul 625**

Die Leuchte wird nach dem Installieren genau wie die Einlegekassetten Typ EK24 oder EK24SK auf die T-Unterkonstruktion gelegt und schließt planeben mit den Kassetten ab. Sie kann jederzeit leicht entfernt werden. Die Unterkonstruktion muss zusätzlich im Bereich der Leuchte abgehängt werden.  
Die Übersicht zeigt, für welches T-Profil System und Modul Leuchten angeboten werden können.

**Lay-in luminaire type EK24 module 625**

The luminaire lay in the substructure after installation like the lay-in tiles type EK24 or EK24SK and is on the same level like the tiles. They can be removed easily any time. The substructure must be suspend separately in the area of the light. The overview shows for which T-profile system and module which luminaires can be offered.

Profiltyp profile type	Modul module	600	625
T24		-	x

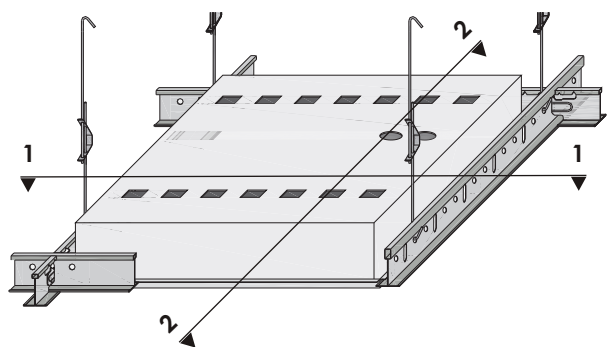

Ansicht 1

View 1

Ansicht 2

View 2

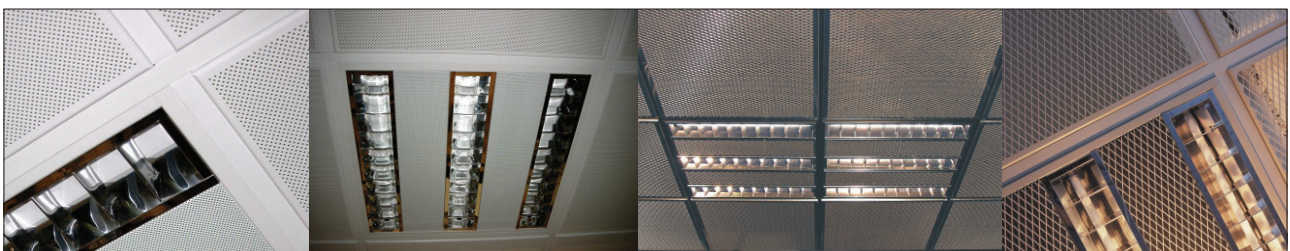
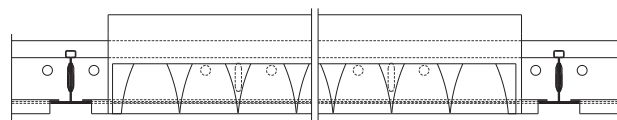
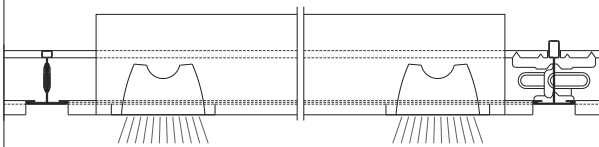

Artikel article			Beschreibung description				
Best.Nr order nr.	Bezeichnung designation	für System for system	Typ type	Schutzart of protection	Lampen lamps	Vorschaltgerät transformer	Maße A dimensions
Leuchte optisch im gleichen Design wie Kassetten Luminaire is in the same surface as the tiles			<b>Spiegelrastereinbauleuchte EK625/24</b> <b>Leuchtgehäuse:</b> • verzinktes Stahlblech <b>Farbe:</b> • Geipel-Standarddeckenweiß, ähnl. RAL 9003 oder ähnl. RAL 9010, andere Farbtöne auf Anfrage <b>Lampentyp:</b> • T16 <b>Spiegelraster (BAP):</b> • Aluminium, hochglanz silber oder weiß, parabolisch geformte Seiten- und Querraster <b>Recessed luminaire with parabolic reflector grid EK625/24</b> <b>Housing:</b> • galvanized steel <b>Colour:</b> • Geipel Standard ceiling colour white similar to RAL 9003 or to RAL 9010, other colours on request <b>Lamp type:</b> • T16 <b>Reflector (BAP):</b> • aluminium, high gloss silver or white, parabolic shaped side and cross grids				
0900691	SEL-TEG 625 2T 16-14E	T24	T5	IP 20	2x14 W	EVG	600 x 600 mm

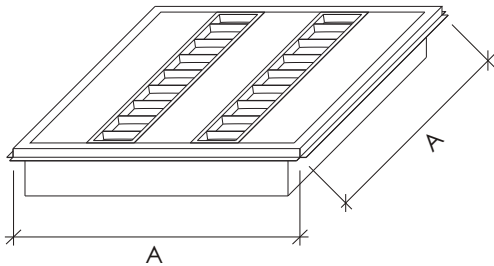

Leuchte optisch im gleichen Design wie Kassetten Luminaire is in the same surface as the tiles			<b>Spiegelrastereinbauleuchte EK625/24</b> <b>Leuchtgehäuse:</b> • verzinktes Stahlblech <b>Farbe:</b> • Geipel-Standarddeckenweiß, ähnl. RAL 9003 oder ähnl. RAL 9010, andere Farbtöne auf Anfrage <b>Lampentyp:</b> • T16 <b>Spiegelraster (BAP):</b> • Aluminium, hochglanz silber oder weiß, parabolisch geformte Seiten- und Querraster <b>Recessed luminaire with parabolic reflector grid EK625/24</b> <b>Housing:</b> • galvanized steel <b>Colour:</b> • Geipel Standard ceiling colour white similar to RAL 9003 or to RAL 9010, other colours on request <b>Lamp type:</b> • T16 <b>Reflector (BAP):</b> • aluminium, high gloss silver or white, parabolic shaped side and cross grids				
0900690	SEL_TEG 625 3T 16-14E	T24	T5	IP 20	3x14 W	EVG	600 x 600 mm

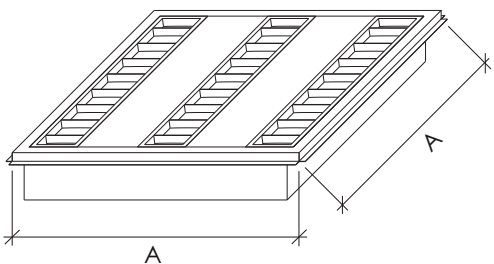

Leuchte optisch im gleichen Design wie Kassetten Luminaire is in the same surface as the tiles			<b>Spiegelrastereinbauleuchte EK625/24</b> <b>Leuchtgehäuse:</b> • verzinktes Stahlblech <b>Farbe:</b> • Geipel-Standarddeckenweiß, ähnl. RAL 9003 oder ähnl. RAL 9010, andere Farbtöne auf Anfrage <b>Lampentyp:</b> • T16 <b>Spiegelraster (BAP):</b> • Aluminium, hochglanz silber oder weiß, parabolisch geformte Seiten- und Querraster <b>Recessed luminaire with parabolic reflector grid EK625/24</b> <b>Housing:</b> • galvanized steel <b>Colour:</b> • Geipel Standard ceiling colour white similar to RAL 9003 or to RAL 9010, other colours on request <b>Lamp type:</b> • T16 <b>Reflector (BAP):</b> • aluminium, high gloss silver or white, parabolic shaped side and cross grids				
0900692	SEL-TEG 625 4T 16-14E	T24	T5	IP 20	4x14 W	EVG	600 x 600 mm

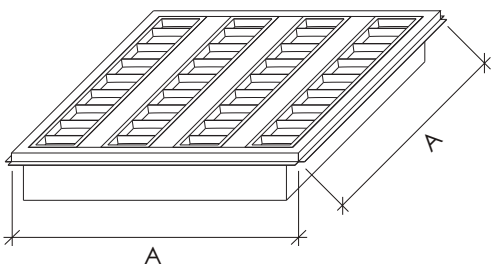

## GEIPEL-Spiegelrastereinbauleuchte Typ EKA

GEIPEL-Recessed luminaires with parabolic reflector grid type EKA



### Einlegeleuchte Typ EKA Modul 600 oder 625

Die Leuchte wird nach dem Installieren genau wie die Einlegekassetten Typ EKA auf die T-Unterkonstruktion gelegt und kann jederzeit leicht entfernt werden. Die Unterkonstruktion muss zusätzlich im Bereich der Leuchte abgehängt werden. Die Übersicht zeigt, für welches T-Profil System und Modul Leuchten angeboten werden können.

Profiltyp profile type	Modul module	600	625
T24		x	x

### Lay-in luminaire type EKA module 600 or 625

The luminaire lay in the T-substructure after installation like the lay-in tiles type EKA and can be removed easily any time. The substructure must be suspend separately in the area of the luminaire. The overview shows for which T-profile system and module which luminaires can be offered.

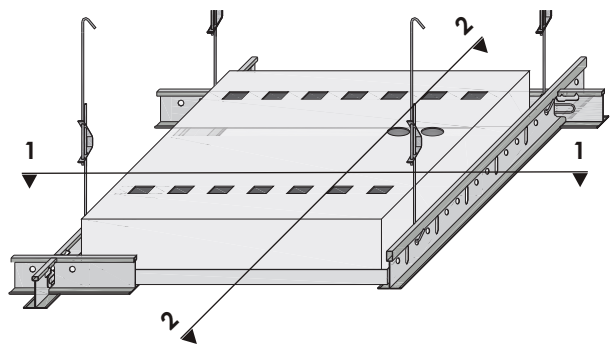

Ansicht 1

View 1

Ansicht 2

View 2

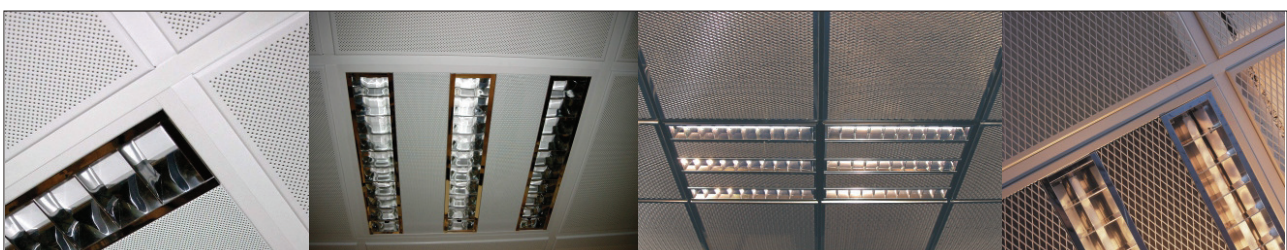
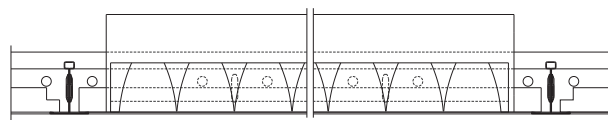
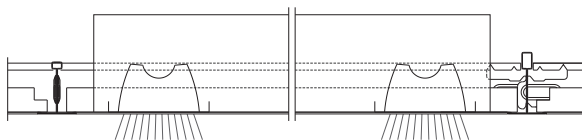

Best.Nr. order nr.			Beschreibung description				
Artikel article	Bezeichnung designation	für System for system	Typ type	Schutzart of protection	Lampen lamps	Vorschaltgerät transformer	Maße A dimensions
Leuchte optisch im gleichen Design wie Kassetten Luminaire is in the same surface as the tiles			<b>Spiegelrastereinbauleuchte EKA600 und EKA625</b>				
			<b>Leuchengehäuse:</b> • verzinktes Stahlblech				
			<b>Farbe:</b> • GEIPEL-Standarddeckenweiß, ähnl. RAL 9003 oder ähnl. RAL 9010, andere Farbtöne auf Anfrage				
			<b>Lampentyp:</b> • T16				
			<b>Spiegelraster (BAP):</b> • Aluminium, hochglanz silber oder weiß, parabolisch geformte Seiten- und Querraster				
			<b>Recessed luminaire with parabolic reflector grid EKA600 und EKA625</b>				
			<b>Housing:</b> • galvanized steel				
			<b>Colour:</b> • GEIPEL Standard ceiling colour white similar to RAL 9003 or to RAL 9010, other colours on request				
			<b>Lamp type:</b> • T16				
			<b>Reflector (BAP):</b> • aluminium, high gloss silver or white, parabolic shaped side and cross grids				
<b>0900702</b>	SEL 600 2T 16-14E	T24	T5	IP 20	2x14 W	EVG	592x592 mm
<b>0900703</b>	SEL 625 2T 16-14E	T24	T5	IP 20	2x14 W	EVG	620x620 mm

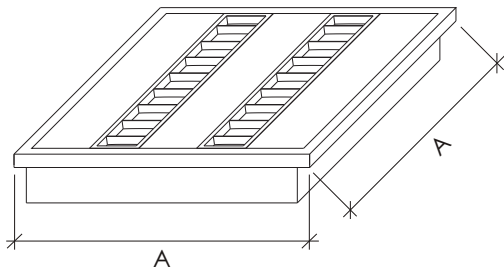

Leuchte optisch im gleichen Design wie Kassetten Luminaire is in the same surface as the tiles			<b>Spiegelrastereinbauleuchte EKA600 und EKA625</b>				
			<b>Leuchengehäuse:</b> • verzinktes Stahlblech				
			<b>Farbe:</b> • GEIPEL-Standarddeckenweiß, ähnl. RAL 9003 oder ähnl. RAL 9010, andere Farbtöne auf Anfrage				
			<b>Lampentyp:</b> • T16				
			<b>Spiegelraster (BAP):</b> • Aluminium, hochglanz silber oder weiß, parabolisch geformte Seiten- und Querraster				
			<b>Recessed luminaire with parabolic reflector grid EKA600 und EKA625</b>				
			<b>Housing:</b> • galvanized steel				
			<b>Colour:</b> • GEIPEL Standard ceiling colour white similar to RAL 9003 or to RAL 9010, other colours on request				
			<b>Lamp type:</b> • T16				
			<b>Reflector (BAP):</b> • aluminium, high gloss silver or white, parabolic shaped side and cross grids				
<b>0900700</b>	SEL 600 3T 16-14E	T24	T5	IP 20	3x14 W	EVG	592x592 mm
<b>0900701</b>	SEL 625 3T 16-14E	T24	T5	IP 20	3x14 W	EVG	620x620 mm

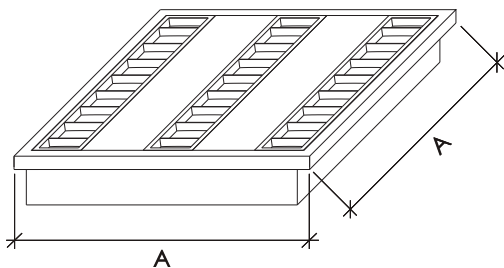

Leuchte optisch im gleichen Design wie Kassetten Luminaire is in the same surface as the tiles			<b>Spiegelrastereinbauleuchte EKA600 und EKA625</b>				
			<b>Leuchengehäuse:</b> • verzinktes Stahlblech				
			<b>Farbe:</b> • GEIPEL-Standarddeckenweiß, ähnl. RAL 9003 oder ähnl. RAL 9010, andere Farbtöne auf Anfrage				
			<b>Lampentyp:</b> • T16				
			<b>Spiegelraster (BAP):</b> • Aluminium, hochglanz silber oder weiß, parabolisch geformte Seiten- und Querraster				
			<b>Recessed luminaire with parabolic reflector grid EKA600 und EKA625</b>				
			<b>Housing:</b> • galvanized steel				
			<b>Colour:</b> • GEIPEL Standard ceiling colour white similar to RAL 9003 or to RAL 9010, other colours on request				
			<b>Lamp type:</b> • T16				
			<b>Reflector (BAP):</b> • aluminium, high gloss silver or white, parabolic shaped side and cross grids				
<b>0900704</b>	SEL 600 4T 16-14E	T24	T5	IP 20	4x14 W	EVG	592x592 mm
<b>0900705</b>	SEL 625 4T 16-14E	T24	T5	IP 20	4x14 W	EVG	620x620 mm

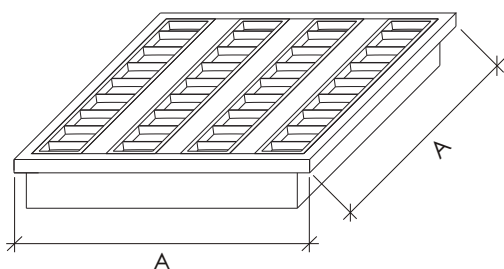



## GEIPEL-Spiegelrastereinbauleuchte Typ EKA

GEIPEL-Recessed luminaire with parabolic reflector grid type EKA



### Einlegeleuchte Typ EKA

#### Modul 600 oder 625

Die Leuchte wird nach dem Installieren genau wie die Einlegekassetten Typ EKA auf die T-Unterkonstruktion gelegt und kann jederzeit leicht entfernt werden. Die Unterkonstruktion muss zusätzlich im Bereich der Leuchte abgehängt werden.

Die Übersicht zeigt, für welches T-Profil System und Modul Leuchten angeboten werden können.

### Lay-in luminaire type EKA

#### module 600 or 625

The luminaire lay in the T-substructure after installation like the lay-in tiles type EKA and can be removed easily any time.

The substructure must be suspend separately in the area of the light. The overview shows for which T-profile system and module which luminaires can be offered.

Profiltyp profile type	Modul module	600	625
T15		x	x
T24		x	x
T35		x	x

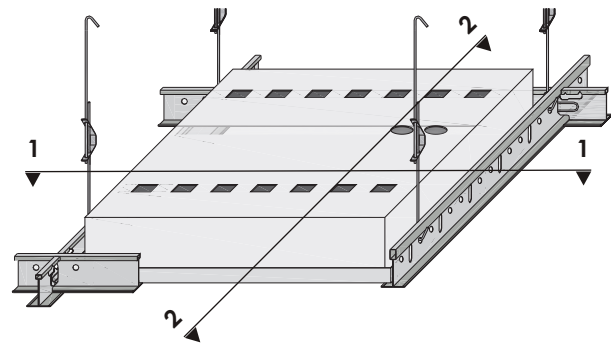

Ansicht 1

View 1

Ansicht 2

View 2

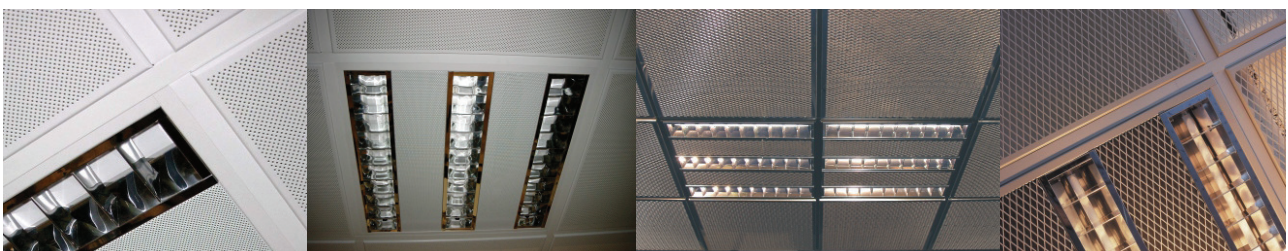
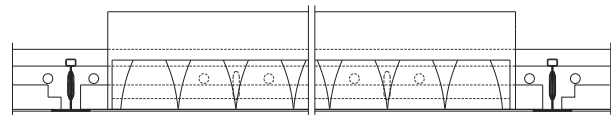
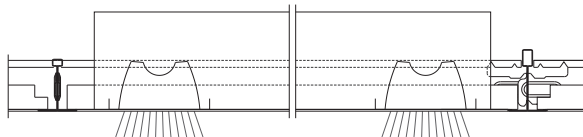

Artikel article			Beschreibung description				
Best.Nr. order nr.	Bezeichnung designation	für System for system	Typ type	Schutzart of protection	Lampen lamps	Vorschaltgerät transformer	Maße A dimensions
Leuchte optisch im gleichen Design wie Kassetten Luminaire is in the same surface as the tiles			<b>Spiegelrastereinbauleuchte EKA600 und EKA625</b> <b>Leuchtgehäuse:</b> • verzinktes Stahlblech <b>Farbe:</b> • Geipel-Standarddeckenweiß, ähnl. RAL 9003 oder ähnl. RAL 9010, andere Farbtöne auf Anfrage <b>Lampentyp:</b> • T16 <b>Spiegelraster (BAP):</b> • Aluminium, hochglanz silber oder weiß, parabolisch geformte Seiten- und Querraster <b>Recessed luminaire with parabolic reflector grid EKA600 und EKA625</b> <b>Housing:</b> • galvanized steel <b>Colour:</b> • Geipel Standard ceiling colour white similar to RAL 9003 or to RAL 9010, other colours on request <b>Lamp type:</b> • T16 <b>Reflector (BAP):</b> • aluminium, high gloss silver or white, parabolic shaped side and cross grids				
<b>0900702</b>	SEL 600 2T 16-14E	T24 / T35	T5	IP 20	2x14 W	EVG	592x592 mm
<b>0900703</b>	SEL 625 2T 16-14E	T15 / T24 / T35	T5	IP 20	2x14 W	EVG	620x620 mm

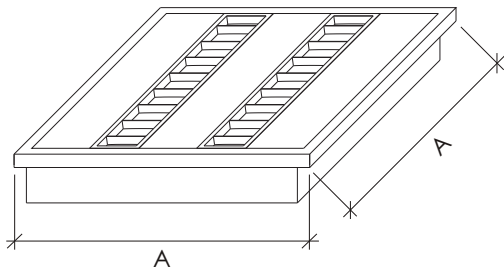

Leuchte optisch im gleichen Design wie Kassetten Luminaire is in the same surface as the tiles			<b>Spiegelrastereinbauleuchte EKA600 und EKA625</b> <b>Leuchtgehäuse:</b> • verzinktes Stahlblech <b>Farbe:</b> • Geipel-Standarddeckenweiß, ähnl. RAL 9003 oder ähnl. RAL 9010, andere Farbtöne auf Anfrage <b>Lampentyp:</b> • T16 <b>Spiegelraster (BAP):</b> • Aluminium, hochglanz silber oder weiß, parabolisch geformte Seiten- und Querraster <b>Recessed luminaire with parabolic reflector grid EKA600 und EKA625</b> <b>Housing:</b> • galvanized steel <b>Colour:</b> • Geipel Standard ceiling colour white similar to RAL 9003 or to RAL 9010, other colours on request <b>Lamp type:</b> • T16 <b>Reflector (BAP):</b> • aluminium, high gloss silver or white, parabolic shaped side and cross grids				
<b>0900700</b>	SEL 600 3T 16-14E	T24 und T35	T5	IP 20	3x14 W	EVG	592x592 mm
<b>0900701</b>	SEL 625 3T 16-14E	T15 / T24 / T35	T5	IP 20	3x14 W	EVG	620x620 mm

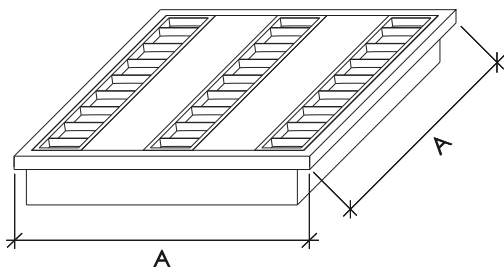

Leuchte optisch im gleichen Design wie Kassetten Luminaire is in the same surface as the tiles			<b>Spiegelrastereinbauleuchte EKA600 und EKA625</b> <b>Leuchtgehäuse:</b> • verzinktes Stahlblech <b>Farbe:</b> • Geipel-Standarddeckenweiß, ähnl. RAL 9003 oder ähnl. RAL 9010, andere Farbtöne auf Anfrage <b>Lampentyp:</b> • T16 <b>Spiegelraster (BAP):</b> • Aluminium, hochglanz silber oder weiß, parabolisch geformte Seiten- und Querraster <b>Recessed luminaire with parabolic reflector grid EKA600 und EKA625</b> <b>Housing:</b> • galvanized steel <b>Colour:</b> • Geipel Standard ceiling colour white similar to RAL 9003 or to RAL 9010, other colours on request <b>Lamp type:</b> • T16 <b>Reflector (BAP):</b> • aluminium, high gloss silver or white, parabolic shaped side and cross grids				
<b>0900704</b>	SEL 600 4T 16-14E	T24 / T35	T5	IP 20	4x14 W	EVG	592x592 mm
<b>0900705</b>	SEL 625 4T 16-14E	T15 / T24 / T35	T5	IP 20	4x14 W	EVG	620x620 mm

